



## CE / CT Centrifugal Fans

**Compact and powerful fan for your professional environment**

- High-Performance
- Compact design
- Simple installation in any position
- Maintenance-free and reliable

[Find more details in our online catalogue](#)

### High performance

The CE/CT series of **centrifugal fans** are designed for **indoor** use with stable power performance for **extract** or **supply** air.

### Compact design

The CE/CT fan has a **compact form factor** and can be installed in **any required position**. This supports various applications (**commercial, industrial** and **residential**).

## Certifications



Ecodesign (ErP) compliant

## Features

### Construction

CE/CT fan casing made of **galvanised** sheet steel, corrosion **class C3**. Shape of the casing designed to obtain high efficiency.

CE fans are equipped with **terminal box IP44** to simplify wiring process on site. CT fans are equipped with **cable** to connect to the external terminal box (separate accessory).

### Impeller

Single inlet **radial** impellers with **forward curved** blades. Made of **lightweight PP** for sizes 125/160 and **galvanised sheet steel** for bigger sizes. All impellers **dynamically balanced** and paired with corresponding external rotor motors.

### Motor

CE/CT fans are equipped with **AC external rotor motor**, insulation **class B**. All motors are supported by **long-life** ball bearings.

### Motor protection

CE Fans have **integrated thermal protection** with **manual (electrical) reset**. CT Fans have **integrated thermal contact** with **external leads** for connection to a **motor protection** device (separate accessory).

### Control

All fans are controlled by **5-step** or **stepless** speed regulator provided as accessory. Speed regulation can be combined with timer, thermostat, hygrostat, etc. by using wide range of electrical accessories.

### Installation

Mounting of the CE/CT fans possible **indoor** in **any mounting position**. CE models used standard inlet and outlet flanges to maximise adaptability with corresponding **FK** fast clamps.

## Technical parameters

### Nominal data

Voltage (nominal)	230	V
Frequency	50	Hz
Phases	1~	
Input power	104	W
Input power kW	0.104	kW
Input current	0.45	A
Impeller speed	1,633	rpm
Air flow	max 396	m³/h
Capacitance of capacitor	2	µF
Temperature of transported air	max 50	°C
Max temperature of transported air, when speed controlled	50	°C

### Sound data

Sound pressure level at 3m (20m² Sabin)	43	dB(A)
---	----	-------

### Protection/Classification

Enclosure class, motor	IP44
Insulation class	B

### Data according to ErP

Energy class, Basic unit	F
Energy class, Local demand	C
ErP ready	ErP 2016; ErP 2018

### Dimensions and weights

Duct dimension; Circular, inlet	125	mm
Duct dimension; Circular, outlet	125	mm
Weight	2.65	kg

### Others

Duct connection type	Circular
Motor type	AC

Performance

Performance curve

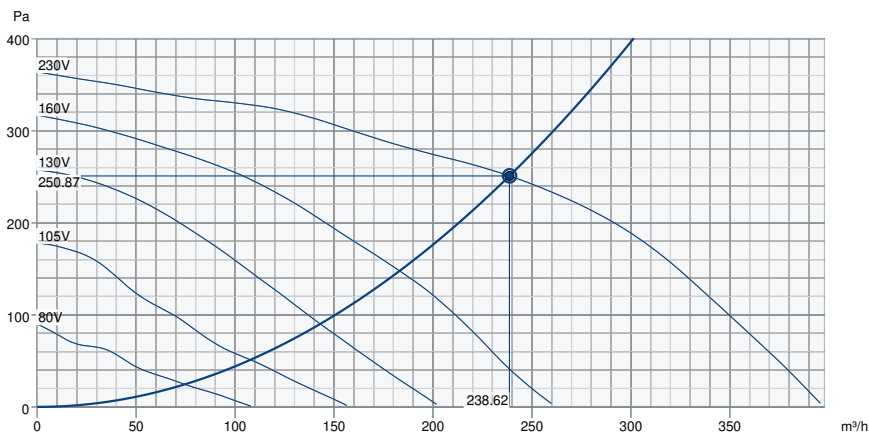

Hydraulic data

Required air flow	239 m³/h
Required static pressure	251 Pa
Working air flow	239 m³/h
Working static pressure	251 Pa
Air density	1.204 kg/m³
Power	84.1 W
Fan control - RPM	2,289 rpm
Current	0.37 A
SFP	1.269 kW/m³/s
Control voltage	230.0 V
Supply voltage	230 V

Sound power level		63	125	250	500	1k	2k	4k	8k	Total
Inlet	dB(A)	50	66	65	61	62	56	53	45	71
Outlet	dB(A)	50	66	65	64	64	59	53	48	71
Surrounding	dB(A)	<10	38	29	42	47	40	35	37	50
Sound pressure level at 3m (20m² Sabine)	dB(A)	-	-	-	-	-	-	-	-	43
Sound pressure level at 3m free field	dB(A)	-	-	-	-	-	-	-	-	29

AMCA Certified Rating statements

- Catalogue Version:

Ecodesign

Product		
Trade name	Systemair	
Product name	CE 140 S-125 Centrifugal Fan	
Basic unit		
ErP compliance	2016	
SEC Average	-9.9	kWh/(m².a)
SEC Cold	-26.3	kWh/(m².a)
SEC Warm	-0.5	kWh/(m².a)
SEC Class	F	
Unit category	RVU	
Unit type	UVU	
Drive	External MSD or VSD	
Heat recovery type	None	
Temperature ratio (UVU)	Not applicable	
qv max	349	m³/h
P max	98	W
Sound power (LWA)	40	dB(A)
qv ref	0.068	m³/s
Ps ref	50	Pa
SPI	0.232	W/(m³/h)
CTRL	1	
MISC	1.1	
x-value	1.5	
External Leakage	5	%
AEC average	290.4	kWh
AHS Cold	290.4	kWh
AEC warm	290.4	kWh
AHS Average	1,715.2	kWh/a
AHS Cold	3,355.3	kWh/a
AHS Warm	775.6	kWh/a

Units with local demand control		
ErP compliance	2018	
SEC Average	-24.5	kWh/(m <sup>2</sup> .a)
SEC Cold	-51.6	kWh/(m <sup>2</sup> .a)
SEC Warm	-9	kWh/(m <sup>2</sup> .a)
SEC Class	C	
Unit category	RVU	
Unit type	UVU	
Drive	External MSD or VSD	
Heat recovery type	None	
Temperature ratio (UVU)	Not applicable	
qv max	349	m <sup>3</sup> /h
P max	98	W
Sound power (LWA)	40	dB(A)
qv ref	0.0679	m <sup>3</sup> /s
Ps ref	50	Pa
SPI	0.232	W/(m <sup>3</sup> /h)
CTRL	0.65	
MISC	1.1	
x-value	1.5	
External Leakage	5	%
AEC average	152.2	kWh
AEC cold	152.2	kWh
AEC warm	152.2	kWh
AHS Average	2,830	kWh/a
AHS Cold	5,536.2	kWh/a
AHS Warm	1,279.7	kWh/a

## Dimension

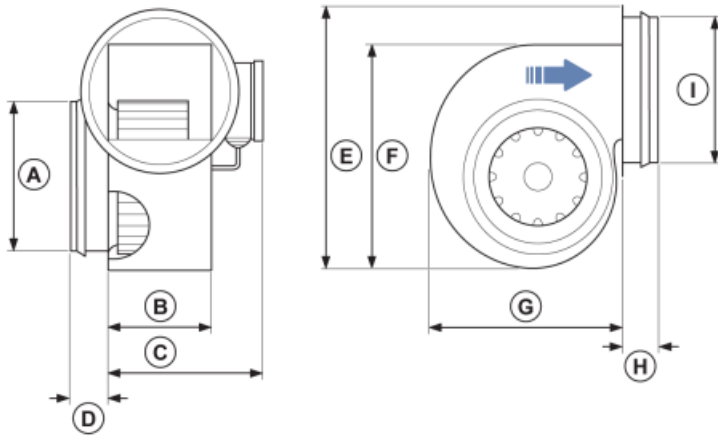

### Wiring

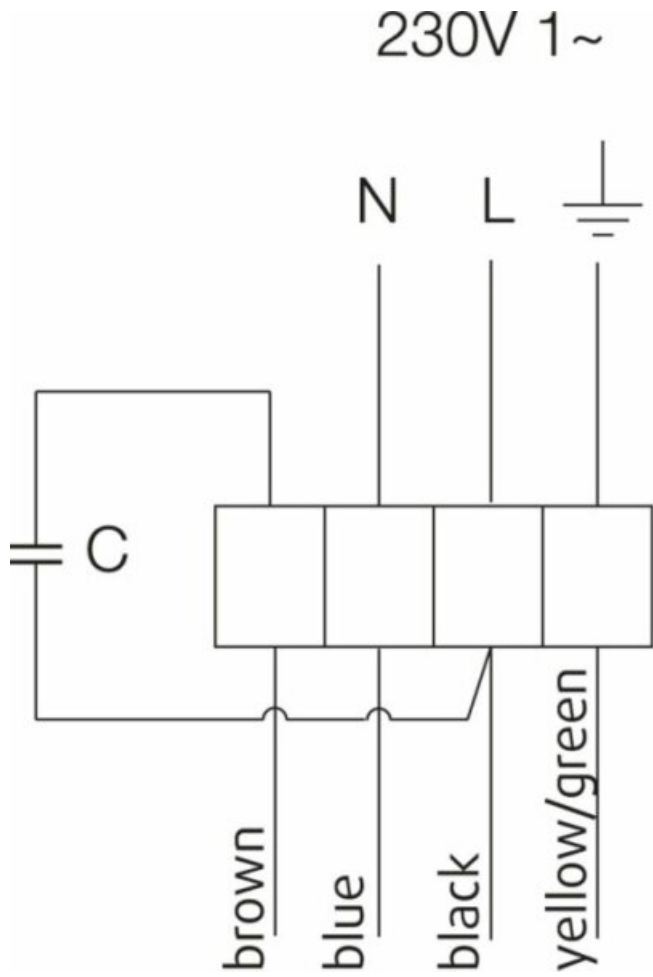



## Energy class label

### Energy class, Basic unit

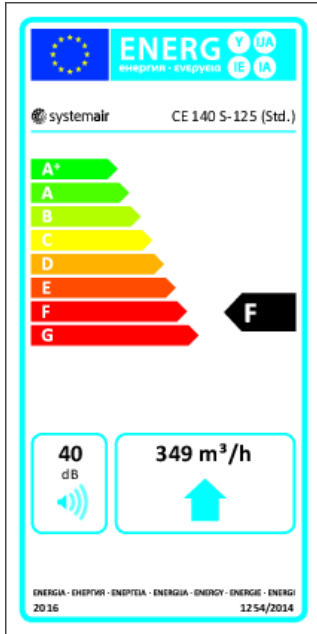

### Energy class, Local demand

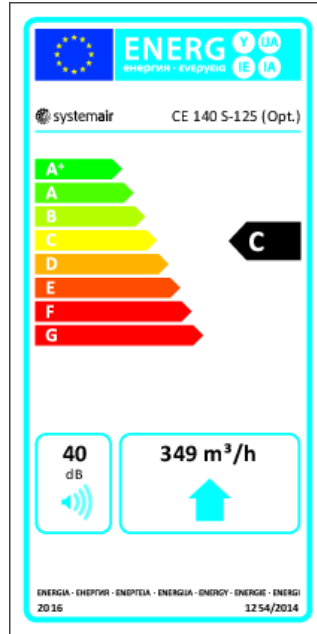

## Accessories

- RE 1,5 Speed control (5000)
- REPT 6 Digital regulator (5698)
- SG 125 Protection guard (5607)
- DTV500A (96807)
- IGK-125 Wall Grid (1631)
- RT 0-30 Room Thermostat (5151)
- T 120 Timer (5165)
- CB 125-1,2 230V/1 Duct heater (5290)
- CBM 125-1,2 230V/1 Duct heater (5480)
- CWK 125-3-2,5 Duct cooler,circ (30021)
- FGR 125 Filter cassette (1804)
- LDC 125-300 Silencer (53722)
- LDC 125-900 Silencer (5191)
- THB 160 Hood w.cover pl. black (1764)
- VBC 125-2 Water heating batt (5457)
- REE 1 Speed control (5314)
- REU 1.5 Speed control (5004)
- VKK-125 Back draft damper (1624)
- HR1 Room Humidistat (215150)
- Presence detector/IR24-P (6995)
- Safety switch 2-pole grey (210679)
- CB 125-0,6 230V/1 Duct heater (5289)
- CB 125-1,8 230V/1 Duct heater (5377)
- CBMF 125-1,2 230V/1 Duct heater (12242)
- FFR 125 Filter cassette (1768)
- FK 125 Fast clamp (1608)
- LDC 125-600 Silencer (5190)
- RSK-125 Back draft damper (5598)
- THS 160 Hood w.cover pl. black (1839)
- VBF 125 Water heating battery (1730)

## Documents

- [INSTALLATION\\_OPERATION\\_AND\\_MAINTENANCE\\_INSTRUCTION\\_CE\\_CT\\_EN\\_006.PDF](#)
- [COMMISSIONING\\_RECORD\\_FANS\\_EN.PDF](#)