

Original instructions  
**Pamir 2500**

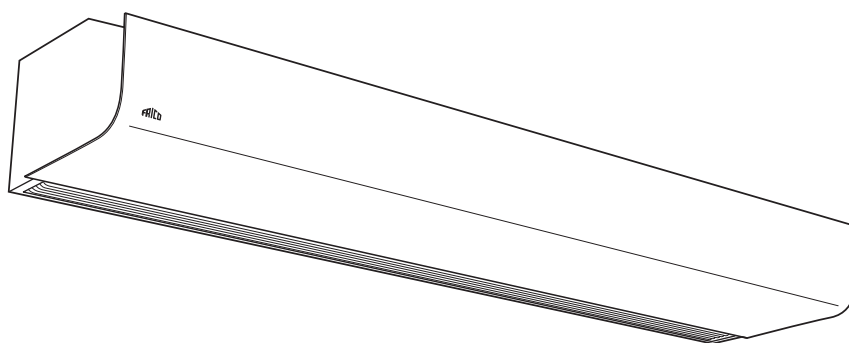

EN .... 13

SE ... 17

NO ... 22

FR ... 27

DE ...32

NL ... 38

ES ...43

IT ...48

PL ... 54

RU ... 59

FI ...65

DK ... 70

- EN The introduction pages consist mainly of pictures. For translation of the English texts used, see the respective language pages.
- SE Introduktionssidorna består huvudsakligen av bilder. För översättning av de engelska texter som används, se respektive språksidor.
- NO Introduksjonssidene består hovedsakelig av bilder. For oversettelse av de engelske tekstene, se de respektive språksidene.
- FR Les pages de présentation contiennent principalement des images. Pour la traduction des textes en anglais, consultez la page correspondante à la langue souhaitée.
- DE Die Einleitungsseiten bestehen hauptsächlich aus Bildern. Für die Übersetzung der verwendeten Texte in englischer Sprache, siehe die entsprechenden Sprachseiten.
- ES Las páginas introductorias contienen básicamente imágenes. Consulte la traducción de los textos en inglés que las acompañan en las páginas del idioma correspondiente.
- NL De inleidende pagina's bevatten hoofdzakelijk afbeeldingen. Voor een vertaling van de gebruikte Engelse teksten, zie de pagina's van de resp. taal.
- IT Le pagine introduttive contengono prevalentemente immagini. Per le traduzioni dei testi scritti in inglese, vedere le pagine nelle diverse lingue.
- PL Początkowe strony zawierają głównie rysunki. Tłumaczenie wykorzystanych tekstów angielskich znajduje się na odpowiednich stronach językowych.
- RU Страницы в начале Инструкции состоят в основном из рисунков, схем и таблиц. Перевод встречающегося там текста приведен в разделе RU.
- FI Esittelysivut koostuvat lähinnä kuvista. Suvuilla olevien enlanninkielisten sanojen käännökset löytyvät ko. kielisivuilta.
- DK Introduktionssiderne består hovedsageligt af billeder. For oversættelse af de engelske tekster, se siderne for de respektive sprog.

# Pamir 2500

PAF2500

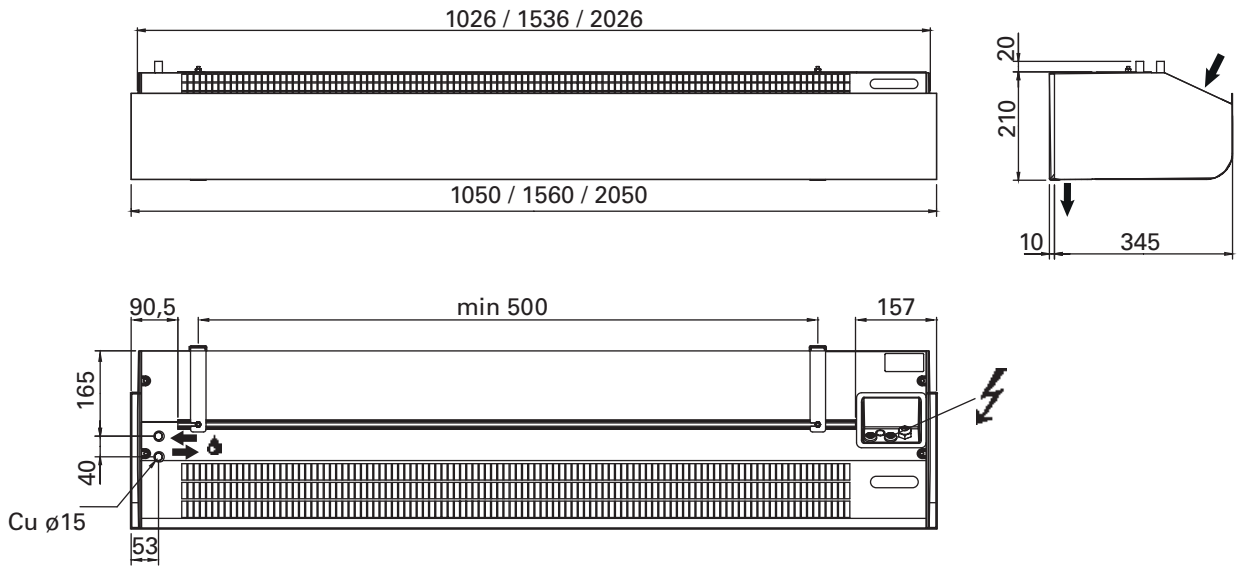

2 m

☪ PAF2500A    💧 PAF2500W

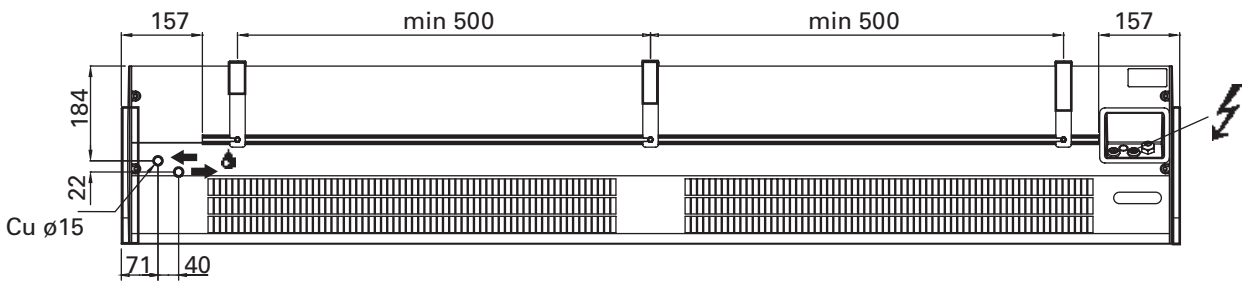

☪ PAF2500E

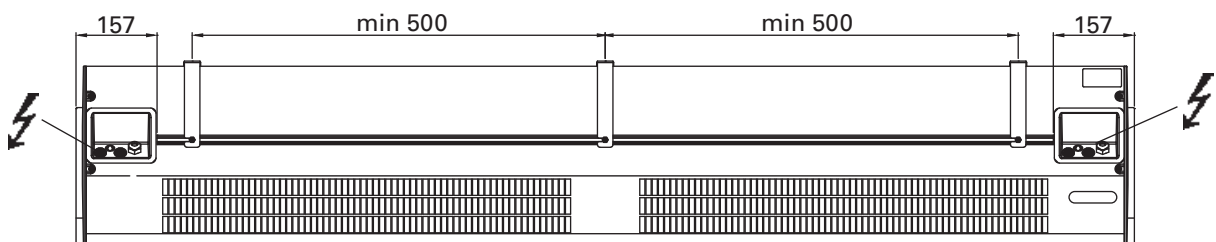

Fig.1

# Pamir 2500

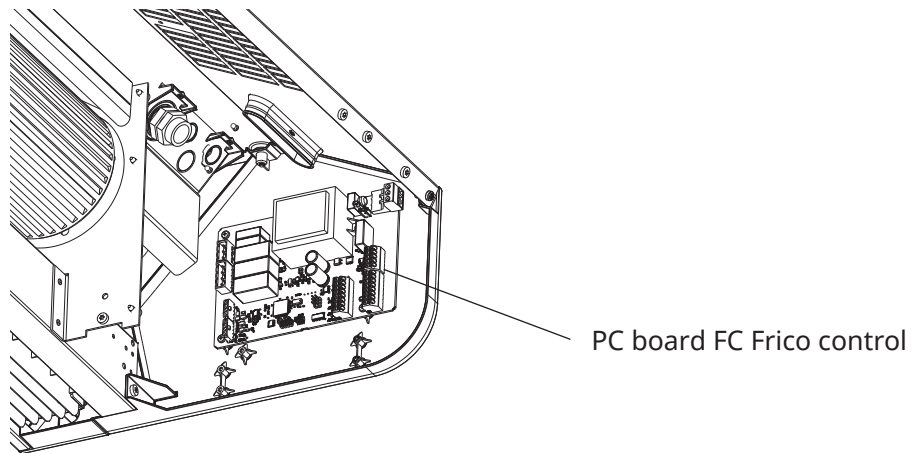
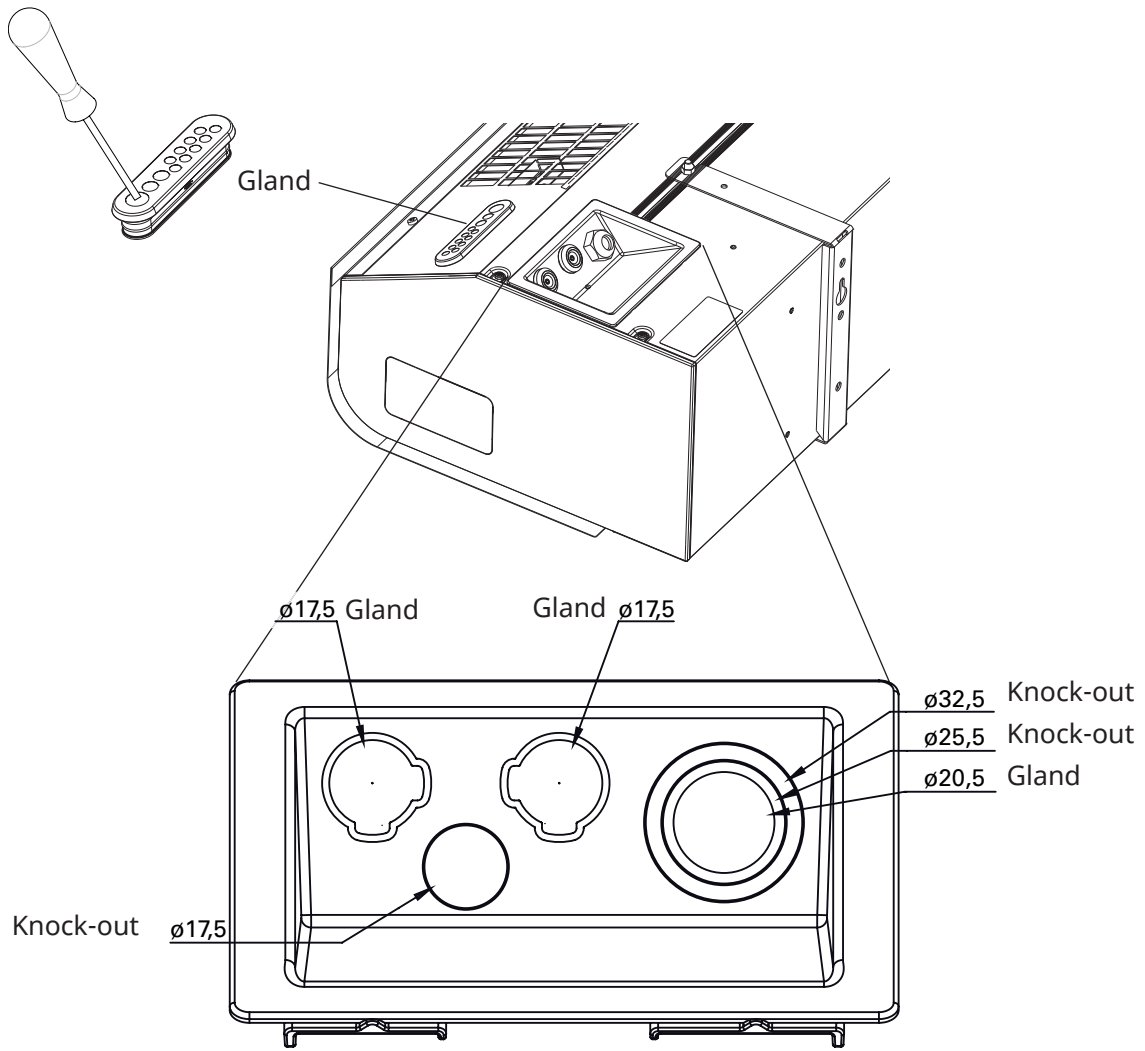

Fig. 2: PC board FC is integrated within the air curtain at delivery.

# Pamir 2500

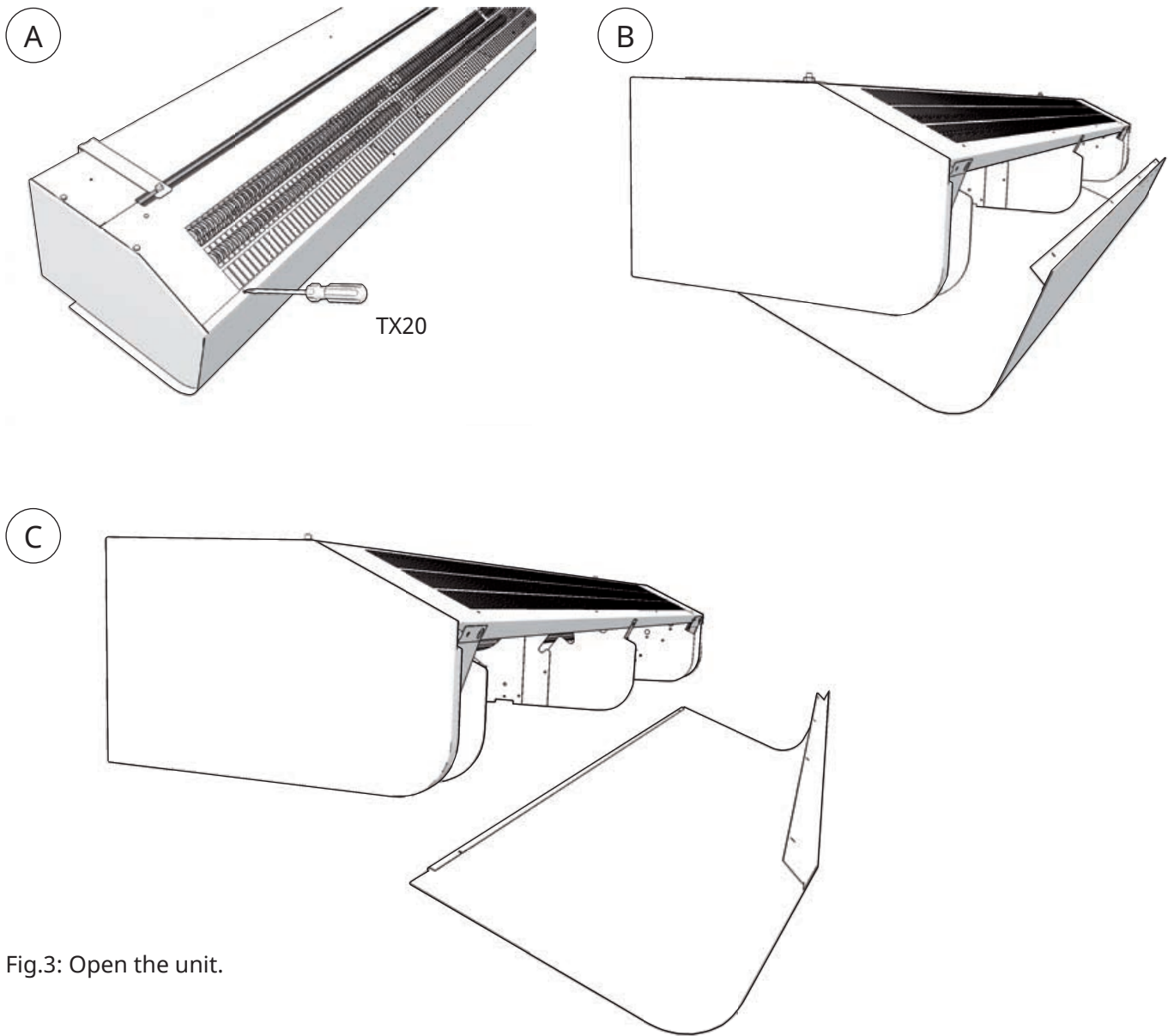

Fig.3: Open the unit.

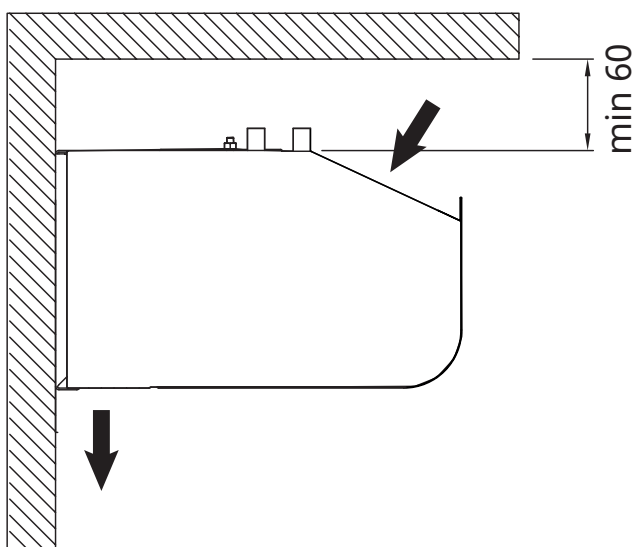
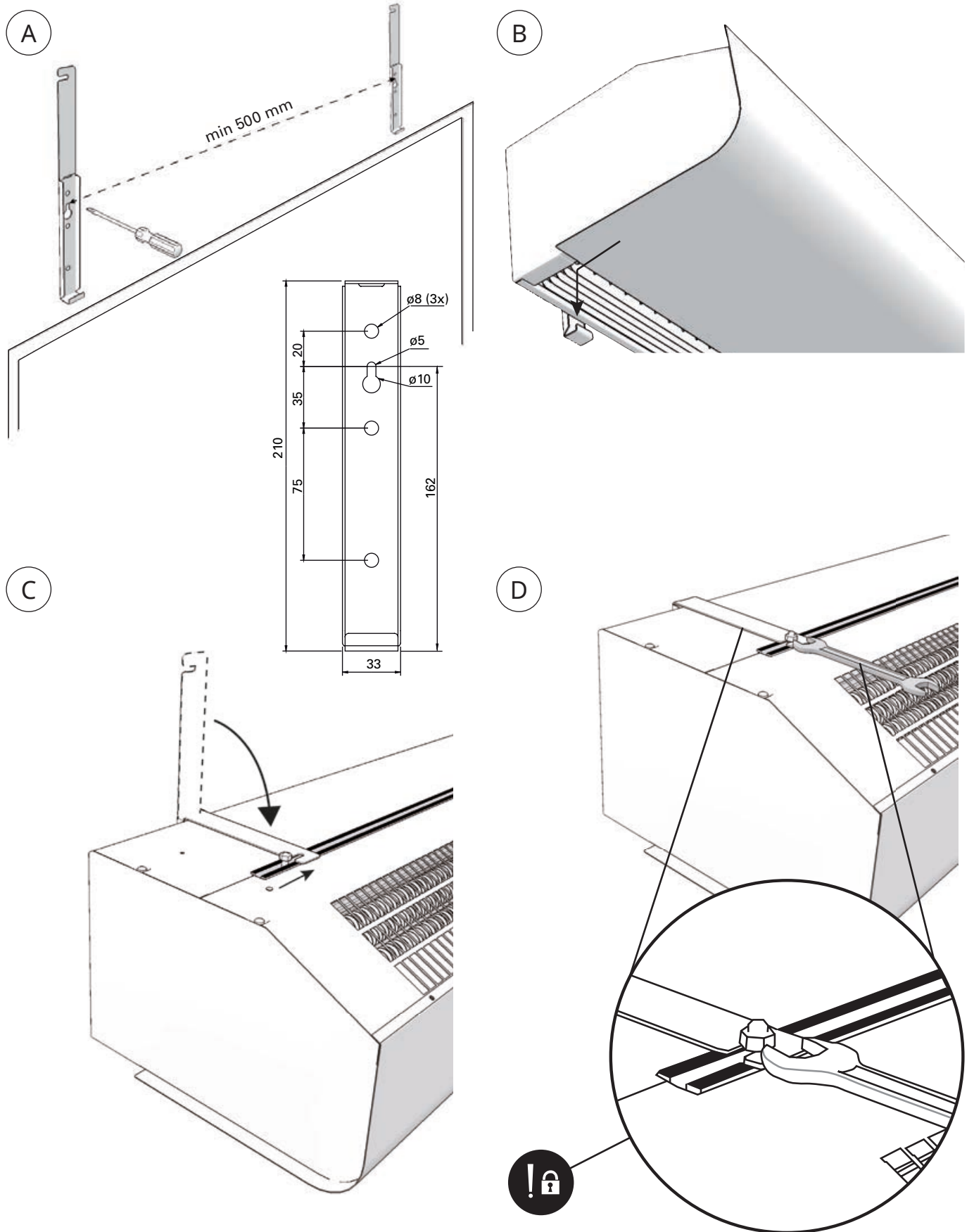

Fig.4: Minimum distance.

Mounting with wall brackets



<b>PAF2510</b>	2 pcs
<b>PAF2515</b>	2 pcs
<b>PAF2520</b>	3 pcs

Fig. 6: Mounting with wall brackets

## Accessories

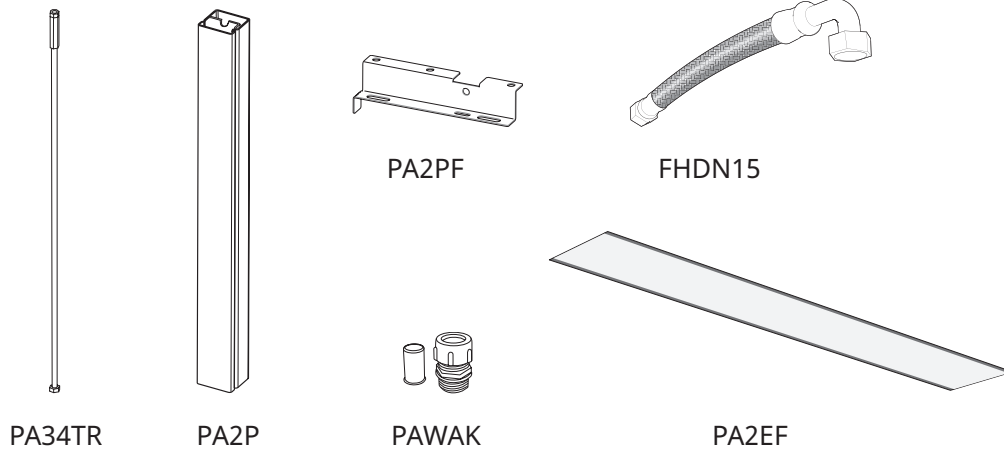

Item number	Type		Consists of	Length
18056	<b>PA34TR15*</b>	PAF2510, PAF2515	4 pcs	1 m
18057	<b>PA34TR20*</b>	PAF2520	6 pcs	1 m
19568	<b>PA2P15*</b>	PAF2510, PAF2515	2 pcs	1m
19569	<b>PA2P20*</b>	PAF2520	3 pcs	1 m
19415	<b>PA2PF15*</b>	PAF2510, PAF2515	4 pcs	
19417	<b>PA2PF20*</b>	PAF2520	6 pcs	
14875	<b>PA2EF10</b>	PAF2510W		
14876	<b>PA2EF15</b>	PAF2515W		
14877	<b>PA2EF20</b>	PAF2520W		
27279	<b>PAWAK</b>	PAF2500W		
77179	<b>FHDN15</b>	PAF2500W		

\*) See separate manual.

## Valve systems

Item number	Type	Connection	Flow range [l/s]
238293	<b>VPFC15LF</b>	DN15	0,012-0,068
238294	<b>VPFC15NF</b>	DN15	0,024-0,13
238295	<b>VPFC20</b>	DN20	0,058-0,32
238296	<b>VPFC25</b>	DN25	0,10-0,60
238297	<b>VPFC32</b>	DN32	0,22-1,03

See separate manual.

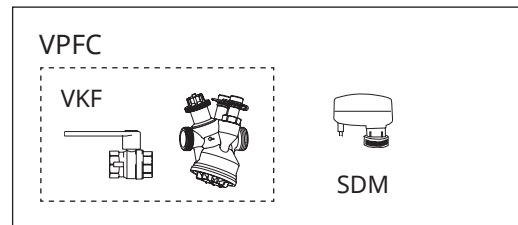

## Control systems

The air curtain must be supplemented with a control system.

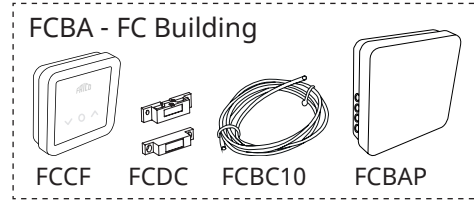
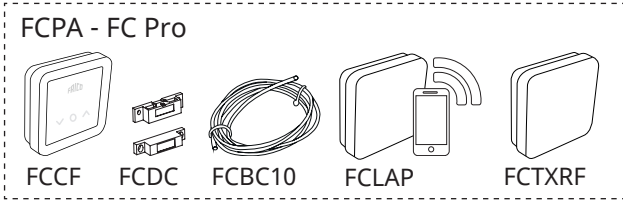
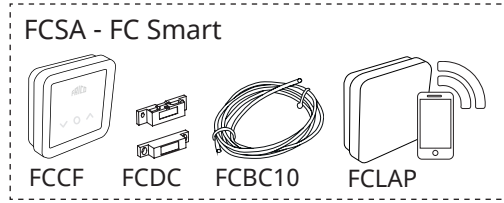
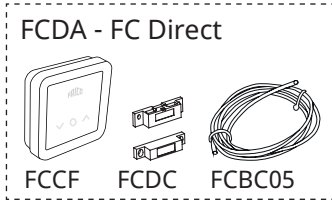

Item number	Type	Name	Dimensions
74684	<b>FCDA</b>	FC Direct	89x89x26 mm (FCCF)
74685	<b>FCSA</b>	FC Smart	89x89x26 mm (FCCF)
74686	<b>FCPA</b>	FC Pro	89x89x26 mm (FCCF)
74687	<b>FCBA</b>	FC Building	89x89x26 mm (FCCF)

## Accessories

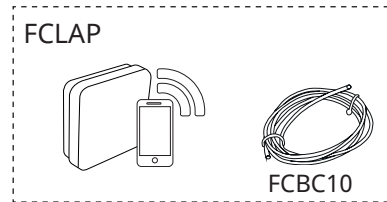
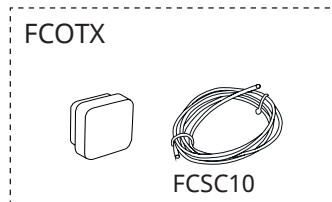
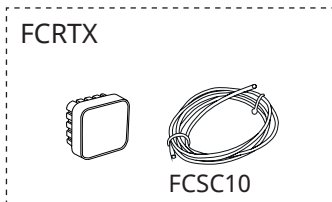

Item number	Type	Dimensions
74694	<b>FCRTX</b>	39x39x23 mm
74695	<b>FCOTX</b>	39x39x23 mm
74699	<b>FCLAP</b>	89x89x26 mm
74702	<b>FCWTA</b> for PAF2500W	
17495	<b>FCDC</b>	
74718	<b>FCBC05</b>	5 m
74719	<b>FCBC10</b>	10 m
74720	<b>FCBC25</b>	25 m
74721	<b>FCSC10</b>	10 m
74722	<b>FCSC25</b>	25 m
74703	<b>FCTXRF</b> for FC Smart, FC Pro	89x89x26 mm

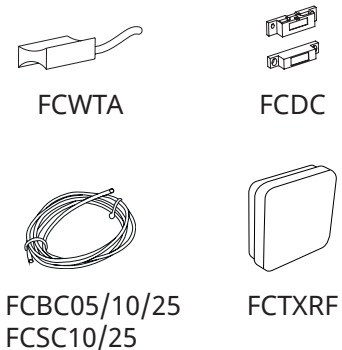

See separate manual for FC.



# Pamir 2500

## PAF2510E / PAF2515E / PAF2520E

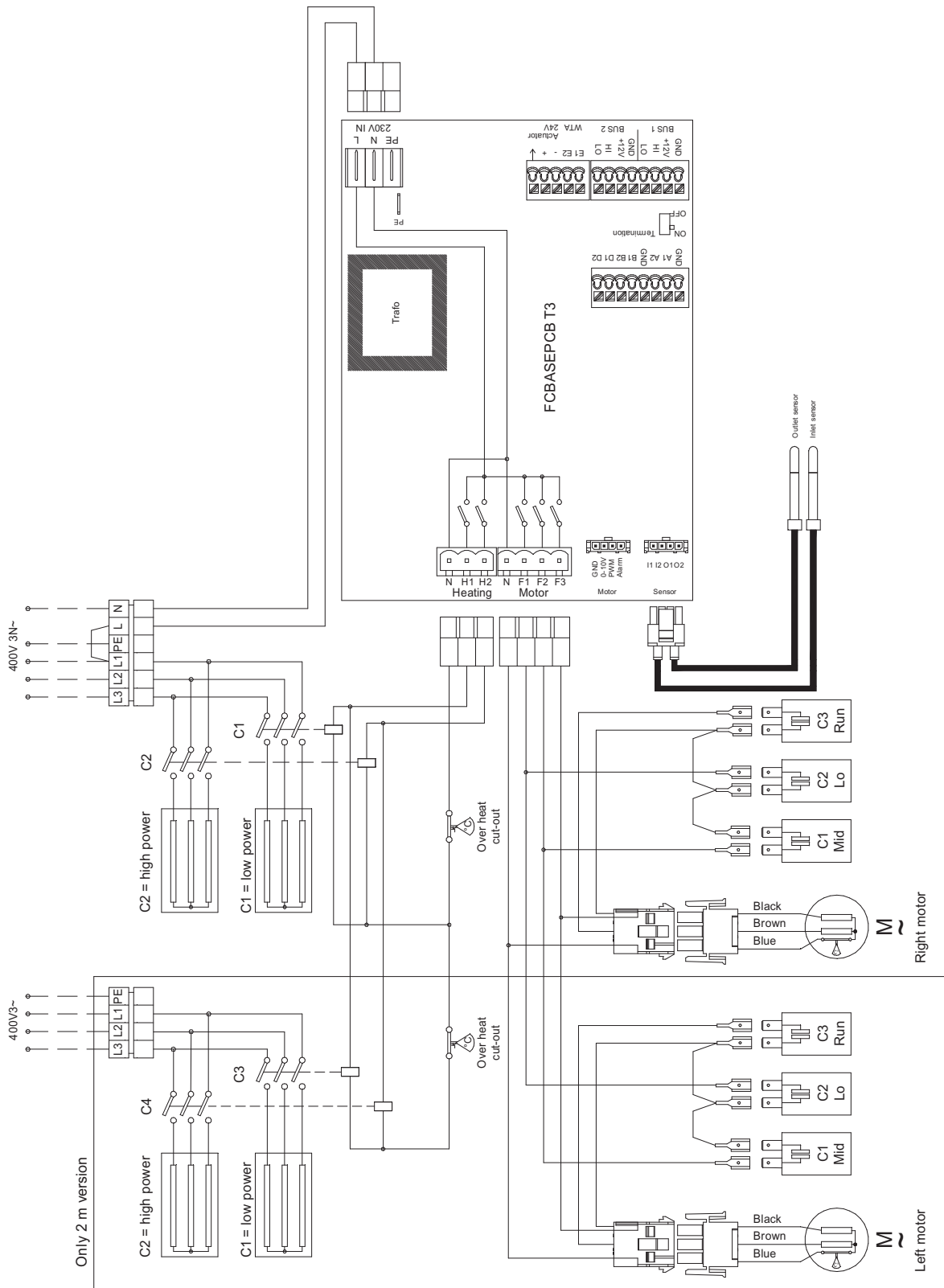

Type	C1 Mid [mF]	C2 Low [mF]	C3 Run [mF]
PAF2510E	10	6	4
PAF2515E	12	8	4
PAF2520E	10	6	4

Wiring diagrams for control system in the FC manual.

# Pamir 2500

PAF2510A / PAF2515A / PAF2520A  
 PAF2510W / PAF2515W / PAF2520W

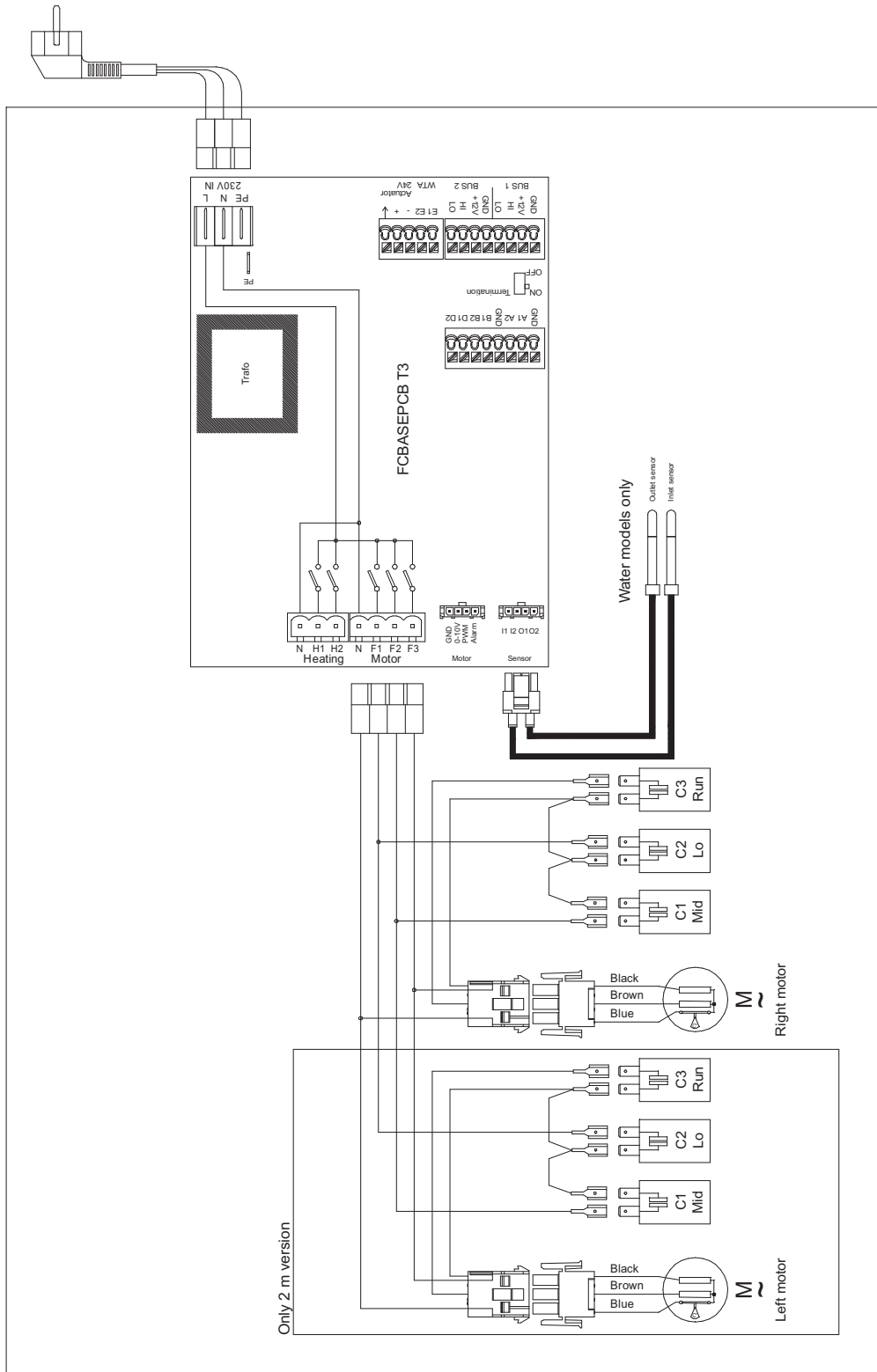

Type	C1 Mid [mF]	C2 Low [mF]	C3 Run [mF]
PAF2510A/W	10	6	4
PAF2515A/W	12	8	4
PAF2520A/W	10	6	4

Wiring diagrams for control system in the FC manual.

# Pamir 2500

PAF2510E05YD / PAF2515E08YD / PAF2520E10YD

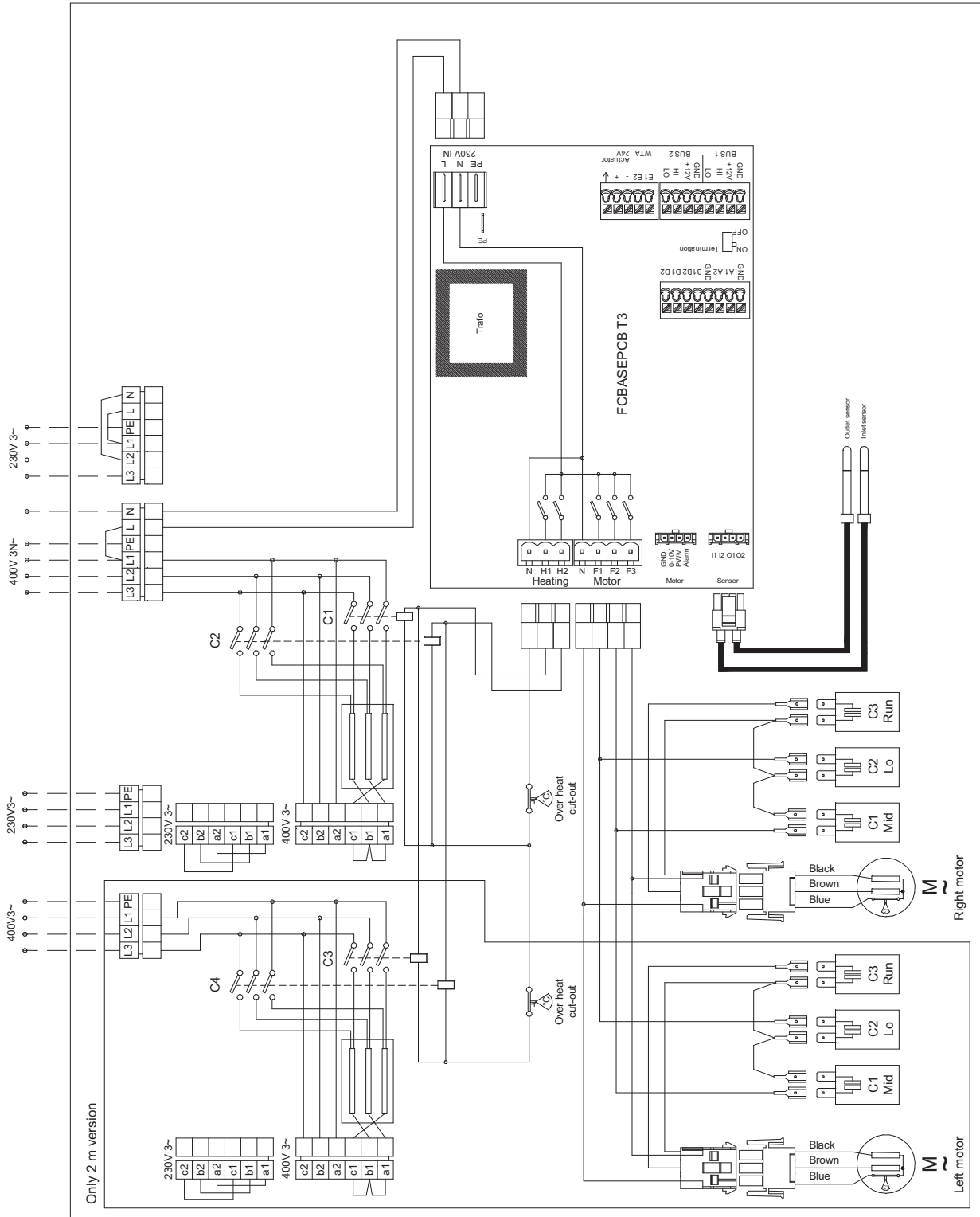

Type	C1 Mid [mF]	C2 Low [mF]	C3 Run [mF]
PAF2510E05YD	10	6	4
PAF2515E08YD	12	8	4
PAF2520E10YD	10	6	4

Wiring diagrams for control system in the FC manual.

Technical specifications Pamir 2500

Voltage motor: 230V~

☼ Ambient, no heat - PAF2500 A (IP21)

Item number	Type	Output [kW]	Airflow*1 [m³/h]	Sound power*2 [dB(A)]	Sound pressure*3 [dB(A)]	Motor [W]	Amperage motor [A]	Weight [kg]
246826	PAF2510A	0	900/1300	70	43/53	115	0,5	16
246830	PAF2515A	0	1250/2100	71	44/54	155	0,7	24
246834	PAF2520A	0	1800/2600	72	44/55	230	1,0	32

⚡ Electrical heat - PAF2500 E (IP20)

Item number	Type	Output steps [kW]	Airflow*1 [m³/h]	$\Delta t^{*4}$ [°C]	Sound power*2 [dB(A)]	Sound pressure*3 [dB(A)]	Motor [W]	Amperage motor [A]	Voltage [V]	Amperage [A] (heat)	Weight [kg]
246823	PAF2510E05	1,7/3,3/5,0	900/1450	17/11	68	42/51	115	0,5	400V3~/7,2	19	
246824	PAF2510E08	3,0/5,0/8,0	900/1450	27/17	68	42/51	115	0,5	400V3~/11,5	20	
246827	PAF2515E08	2,7/5,3/8,0	1400/2200	18/11	69	40/52	115	0,7	400V3~/11,5	30	
246828	PAF2515E12	4,0/8,0/12	1400/2200	26/17	69	40/52	155	0,7	400V3~/17,3	32	
246831	PAF2520E10	3,4/6,6/10	1800/2900	17/11	70	43/53	230	1,0	400V3~/14,4	36	
246832	PAF2520E16	6,0/10/16	1800/2900	27/17	70	43/53	230	1,0	400V3~/23,1	40	

💧 Water heat - PAF2500 W (IP21)

Item number	Type	Output*5 [kW]	Airflow*1 [m³/h]	$\Delta t^{*4,5}$ [°C]	Water volume [l]	Sound power*2 [dB(A)]	Sound pressure*3 [dB(A)]	Motor [W]	Amperage motor [A]	Weight [kg]
246825	PAF2510W	4,7	900/1300	12/11	0,7	69	42/53	105	0,45	18
246829	PAF2515W	9,2	1250/2100	16/13	1,1	70	41/54	140	0,6	26
246833	PAF2520W	11	1800/2600	15/13	1,4	71	43/55	210	0,9	35

⚡ Electrical heat - PAF2500 E 230V3~ (IP20)

Item number	Type	Output steps [kW]	Airflow*1 [m³/h]	$\Delta t^{*4}$ [°C]	Sound power*2 [dB(A)]	Sound pressure*3 [dB(A)]	Amp. motor [A]	Voltage heat [V]	Amp. heat [A]	Weight [kg]
246835	PAF2510E05YD	1,7/3,3/5,0	900/1450	17/11	68	42/51	0,5	230V3~/400V3~	12,6/7,2	19
246836	PAF2515E08YD	2,7/5,3/8,0	1400/2200	18/11	69	40/52	0,7	230V3~/400V3~	20,1/11,5	20
246837	PAF2520E10YD	3,4/6,6/10	1800/2900	17/11	70	43/53	1,0	230V3~/400V3~	25,1/14,4	40



\*1) Lowest/highest airflow of totally 3 fan steps.

\*2) Sound power ( $L_{WA}$ ) measurements according to ISO 27327-2: 2014, Installation type E.

\*3) Sound pressure ( $L_{pA}$ ). Conditions: Distance to the unit 5 metres. Directional factor: 2. Equivalent absorption area: 200 m². At lowest/highest airflow.

\*4)  $\Delta t$  = temperature rise of passing air at maximum heat output and lowest/highest airflow.

\*5) Applicable at water temperature 60/40 °C, air temperature, in +18 °C. See [www.frico.net](http://www.frico.net) for additional calculations.

## Installation and operating instructions

### General Instructions

Read these instructions carefully prior to installation and use. Keep this manual for future reference.

*The product may only be used as set out in the assembly and operating instructions. The guarantee is only valid should the product be used in the manner intended and in accordance with the instructions.*

### Application

Pamir 2500 has a recommended installation height of 2,5 m. The air curtain is available without heat, with electrical heating and with water heating. Protection class for units with electrical heating: IP20.

Protection class for units without heating and units with water heating: IP21.

### Operation

Air is drawn in at the top of the unit and blown downwards shielding the door opening and minimizing heat loss. To achieve the optimum curtain effect the unit must extend the full width of the door opening.

The grille for directing the outlet air is adjustable and is normally angled outwards to achieve the best protection against incoming air.

The efficiency of the air curtain depends on the air temperature, the pressure differential across the doorway and any wind load.

*NOTE! Negative pressure in the building considerably reduces the efficiency of the air curtain. The ventilation should therefore be balanced.*

### Mounting

The air curtain is installed horizontally with the outlet air grille facing downwards as close to the door as possible. The product must be mounted in such a way to allow future service and maintenance. Minimum distance from outlet to floor for electrically heated units is 1800 mm. For other minimum distances, see fig. 4.

#### *Mounting with wall brackets (fig. 6)*

1. Mount the brackets on the wall, see fig.6A and dimension drawing fig.1. If the wall is uneven the brackets must be compensated for this.

2. Hook on the unit at the lower edge of the brackets. (Fig.6B)
3. Bend the top of the console over the the unit and slide the units screws along the rail into the slots on the consoles. (Fig.6C) When the bracket is bent once, it must be replaced if bent back more than 45 °.
4. Lock the nuts against the brackets. (Fig.6D)

#### *Horizontal mounting on the ceiling*

Threaded rods, hanging brackets and ceiling mounting brackets for ceiling mounting are available as accessories, see accessories pages and separate manuals.

### Electrical installation

The installation, which should be preceded by an isolator switch with a contact separation of at least 3 mm, should only be wired by a competent electrician and in accordance with the latest edition of IEE wiring regulations.

The air curtain has an integrated PC board which is connected to the selected external control system FC. FC must be ordered separately. The PC board is accessed via cable glands on the top of the unit. See Fig. 2. FC is supplied pre-programmed. Communication- and sensor cables are connected to the PC board.

Should more than one air curtain be controlled by a single FC, an additional communication cable FCBC per unit will be required. See manual for FC.

#### *Unit without heating or with water heating*

Connected via the built-in control board with 1,5 m cord and plug.

#### *Unit with electrical heating*

The electrical connection is made on the top of the unit. Pierce the gland with a screwdriver before entering the cable. See Fig. 2. Control (230V~) and power supply for heat (400V3~) should be connected to a terminal block in the terminal box. 2-metre and longer units require dual power supplies. See dimension drawings.

The largest cable diameter for the terminal block is 16 mm<sup>2</sup>. The cable glands used must meet the protection class requirements. In the distribution board, it is to be indicated that "the air curtains can be supplied from more than one connection".

Type	Output Voltage		Minimum area* [mm <sup>2</sup> ]
	[kW]	[V]	
<b>Control</b>	0	230V~	1,5
<b>PAF2510E05</b>	5	400V3~	1,5
<b>PAF2510E08</b>	8	400V3~	2,5
<b>PAF2515E08</b>	8	400V3~	2,5
<b>PAF2515E12</b>	12	400V3~	4
<b>PAF2520E10*<sup>1</sup></b>	5	400V3~	1,5
	5	400V3~	1,5
<b>PAF2520E16*<sup>1</sup></b>	8	400V3~	2,5
	8	400V3~	2,5

\*<sup>1</sup>) 2 m units are connected with two power supplies.

\*<sup>2</sup>) Dimensioning of external wiring shall comply with applicable regulations and local deviations may occur.

### Start-up (E)

When the unit is used for the first time or after a long period of non-use, smoke or an odour may result from dust or dirt which has collected on the element. This is completely normal and disappears after a short time.

### Connecting the water coil (W)

The installation must be carried out by an authorised installer.

The water coil has copper tubes with aluminium fins and is suitable for connection to a closed water heating system. The heating coil must not be connected to a mains pressure water system or an open water system.

Note that the unit shall be preceded by a regulating valve, see Frico valve kit.

Valves must be installed outside the unit. Note that the actuator needs power supply and control signal from the integrated PC board. The water coil is connected on the upper side of the unit with  $\varnothing 15$  mm smooth copper pipe with a suitable coupling and internal liner. Soldering is not recommended. The connections to the heating coil must be equipped with shut off valves to allow trouble-free removal. The water coil is equipped with a drain valve. A vent valve should be connected at a high point in the pipe system. Air valves are not included.



NOTE: Care must be taken when connecting the pipes. Always use an internal liner in the pipe connections to prevent straining of the pipes and subsequent water leakage.

### Adjustment of the air curtain and airflow

The direction and speed of the airflow should be adjusted considering the load on the opening. Pressure forces affect the airstream

and force it inwards towards the premises (when the premises are heated and the outdoor air is cold).

The airstream should, therefore, be directed outwards to withstand the load. Generally speaking, the higher the load, the greater the angle required.

### Basic setting fan speed

The fan speed when the door is open is set using the control. Note that the airflow direction and the fan speed may need fine adjustment depending on the loading of the door.

### Filter (W)

The water coil is protected against dirt and blockage by an internal air filter which covers the coil face. In environments where the filter requires frequent cleaning, it is advisable to use an external intake filter (see accessories pages), which provides easier maintenance, since the unit does not need to be opened. When an external filter is used, the internal filter is removed.

### Service, repairs and maintenance

For all service, repair and maintenance first carry out the following:

1. Disconnect the power supply.
2. The front hatch is removed by removing the screws on the top of the unit and then detach the bent edge at the bottom. (Fig.3)
3. After the service, repair and maintenance reattach the front hatch. Place the hatch at the lower edge with the bent edge and fasten on top with screws.

Note that when carrying out work where the end is removed, the outlet grille also detaches.

### Maintenance

#### Unit with water heating

The appliance filter should be cleaned regularly to ensure the air curtain effect and heat emission from the device. How often depends on local circumstances. A clogged filter is not a risk, but the appliance function can fail.

1. Disconnect the power supply.
2. The front hatch is removed by removing the screws on the top of the unit and then detach the bent edge at the bottom. (Fig.3)
3. Remove the filter and vacuum clean or wash it. If the filter is clogged or damaged, it may need to be changed.

*All units*

Since fan motors and other components are maintenance-free, no maintenance other than cleaning is necessary. The level of cleaning can vary depending on local conditions. Undertake cleaning at least twice a year. Inlet and exhaust grilles, impeller and elements can be vacuum cleaned or wiped using a damp cloth. Use a brush when vacuuming to prevent damaging sensitive parts. Avoid the use of strong alkaline or acidic cleaning agents.

**Temperature control**

Temperature control of FC maintains the exhaust temperature. Should the temperature exceed the preset value, the overheating alarm will activate. For more information see the FC manual.

**Overheating***Unit with electrical heating*

The air curtain unit with electrical heating is equipped with an overheat protection. If it is deployed due to overheating, reset as follows:

1. Disconnect the power supply with the isolator switch.
2. Determine the cause of overheating and rectify the fault.
3. Remove the front hatch.
4. Press the red button located inside the air curtain unit, at the inner gable of the terminal box.
5. Reattach the front hatch and connect the unit again.

*All units*

All motors are equipped with an integral thermal safety cut-out. This will operate, stopping the air curtain should the motor temperature rise too high. The cut-out will automatically reset when the motor temperature has returned to within the motor's operating limits.

**Replacing heating elements/heating package (E)**

1. Mark and disconnect the cables to the heating elements/package.
2. Remove the mounting screws securing the heating elements/package in the unit and lift the heating elements/package out.
3. Install the new heating elements/package in reverse order to the above.

**Replacing the water coil (W)**

1. Shut off the water supply to the unit.
2. Disconnect the connections to the water coil.
3. Remove the mounting screws securing the coil in the unit and lift out.
4. Install the new coil in reverse order to the above.

**Draining the water coil (W)**

The drain valve is on the underside of the coil on the connector side. It can be accessed via the front hatch.

**Replacing motor or impeller**

1. Remove the front.
2. Remove gable end.
3. Remove the screw between motor and fan.
4. Disconnect the cables to the motor.
5. Remove the screws securing the motor and lift it out together with the impeller.
6. Install the new motor and/or the new impeller as above in reverse order.

**Replacing the PC board**

1. The PC board is located in the terminal box. Fig. 2
2. Mark and disconnect the cables to the PC board.
3. Remove the screws securing the board and lift out.
4. Install the new PC board as above in reverse order.

**Troubleshooting**

*If the fans are not running or do not perform properly, check the following:*

- The power supply.
- That the intake grille/filter is not dirty.
- That the motor's safety cut-out has not been deployed.
- Functions and settings of the FC control system, see the FC manual.

*If there is no heat, check the following:*

- Functions and settings of the FC control system, see the FC manual.

*For units with electrical heating, also check the following:*

- Power supply to electric heater coil; check fuses and circuit-breaker (if any).
- That the overheat protection has not been deployed.

For units with a water coil, also check the following:

- That the water coil is air free.
- That there is sufficient water flow and pressure.
- That incoming water is heated adequately.

If the fault cannot be rectified, please contact a qualified service technician.

### **Residual current circuit breaker (E)**

When the installation is protected by means of a residual current circuit breaker, which trips when the appliance is connected, this may be due to moisture in the heating element. When an appliance containing a heater element has not been used for a long period or stored in a damp environment, moisture can enter the element.

This should not be seen as a fault, but is simply rectified by connecting the appliance to the main supply via a socket without a safety cut-out so that the moisture can be eliminated from the element. The drying time can vary from a few hours to a few days. As a preventive measure, the unit should occasionally be run for a short time when it is not being used for extended periods of time.

### **Packaging**

Packaging materials are chosen with consideration to the environment and are therefore recyclable.

### **Handling of product at end of working life**

This product may contain substances necessary for the functionality of the product but potentially dangerous for the environment. The product should not be disposed of mixed with general household waste but delivered to a designated collection point for environmental recycling. Please contact the local authority for further details of your nearest designated collection point.

### **Safety**

- For all installations of electrically heated products a residual current circuit breaker 300 mA for fire protection should be used.
- Keep the areas around the air intake and exhaust grilles free from possible obstructions!
- The unit must not be fully or partially covered as overheating can result in a fire risk!
- Lifting equipment must be used to lift the unit.
- This appliance can be used by children aged from 8 years and above and persons with reduced physical, sensory or mental capabilities or lack of experience and knowledge if they have been given supervision or instruction concerning use of the appliance in a safe way and understand the hazards involved. Children shall not play with the appliance. Cleaning and user maintenance shall not be made by children without supervision.
- Children of less than 3 years should be kept away unless continuously supervised.
- Children aged from 3 years and less than 8 years shall only switch on/off the appliance provided that it has been placed or installed in its intended normal operating position and they have been given supervision or instruction concerning use of the appliance in a safe way and understand the hazards involved.
- Children aged from 3 years and less than 8 years shall not plug in, regulate and clean the appliance or perform user maintenance.

**CAUTION — Some parts of this product can become very hot and cause burns. Particular attention has to be given where children and vulnerable people are present.**





**Main office**

Frico AB  
Industrivägen 41  
SE-433 61 Sävedalen  
Sweden

Tel: +46 31 336 86 00

mailbox@frico.se

www.frico.net

**For latest updated information and information  
about your local contact: [www.frico.net](http://www.frico.net).**